

## AR8200 Series 2 Service manual errors.

Several errors and inconsistencies are present in the circuit diagrams in this manual. Most are related to the 'overall diagram' on page 45.

The main circuit information can be taken as accurate and correct and any inconsistencies have been introduced in the overall diagram.

Connectors J504 & J508. The pin numbers for both of these connectors have been reversed in the overall diagram relative to the main circuit diagram. Although pin numbers are not actually present on the board and the overall diagram states which view this is from, it makes circuit tracing using both diagrams very difficult.

J501. In the overall diagram, pin order is correct up to J501-10. The next pin is then labelled J501-30 when it should be J501-11. Consequently, all the remaining pin numbers are then one out of sequence. i.e. J501-11 should be J501-12, J501-12 should be J501-13, etc.

Be aware that, at the connections between J302 and J501, the pin order reverses. i.e. pin1 goes to pin 30 and pin 30 goes to pin 1. Both overall and main circuit diagrams are consistent here.

Note; The AR8200 series 2 service manual now in production is intended for later series 2 sets. There are few differences between earlier and later series 2 sets. One point to be aware of is the wiring differences between connectors J510 and J504/8.

SERIES 2 later wiring is;

Connector	Pin No.									
J510	1	2	3	4	5	6	7	8	9	10
J504/8	16	17	18	19	10	J509/2	22	23	24	3
						Via C517				

SERIES 2 early wiring differ in that;

J510-5 goes to J508-20  
J510-10 to J508-25  
(both grounded).

## **AR8200 Series 2 Aux connector changes.**

In recent AR8200 series 2 units, a small change has occurred to the internal wiring of the 10 pin AUX socket. This is due to the re-assigning of the original AGC pin as 'S' meter and the addition of a proper AGC signal and AGC switch. These have been added at the expense of two pins which were previously grounded.

The AGC output gives a DC voltage level which reduces with respect to input signal level increase. The 'S' meter (previously labelled agc) output increases with signal level.

The 'AGC switch' is a 4v level which if grounded will disconnect the internally produced AGC level allowing it to fall to 0V (i.e. giving a large level of attenuation).

This also allows an external AGC signal to be fed to the set via the AUX AGC connection above.

Unfortunately there is no exact change over date or serial number break but all series 2 units after approximately November 2000 incorporate the change. Early series 2 sets have identical connections to series 1 sets.

Case colour for series 1 sets is green.

Case colour for both early and later series 2 sets is black.

Internally the later sets will be fitted with boards marked 82BCPU2 and 82BPS2 (these are all slightly different to earlier sets with track and component changes – they are not interchangeable).

## **AR8200 accessory lead.**

Pay particular attention to the earth connections used.

Earth connections for **series 1 and early series 2** sets are

SHIELD  
YELLOW  
BLUE  
VIOLET

Page 117 in the operation hand book referring to the wiring colours of this lead is now therefore incorrect for later sets.

This should be revised to;

### **For later series 2 sets;**

RED	+4.2V
BLACK	RXD
BLUE	AGC SWITCH
BROWN	MUTE
ORANGE	S METER
SHIELD	GROUND
WHITE	TXD
YELLOW	GROUND
GREEN	AUDIO OUT
GREY	DETECTOR OUT
PURPLE	AGC

## CC8200 lead changes

The above changes to the AR8200 wiring have resulted in a slight change to the CC8200 computer control lead wiring.

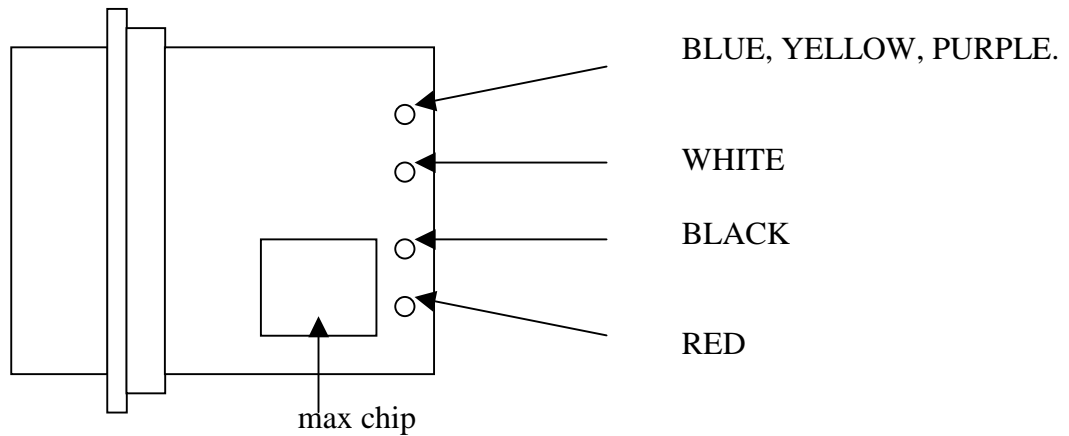

### 9PIN D CONNECTIONS

For later AR8200 series 2 units, the purple wire has been used to provide an AGC signal from the radio. Early CC8200 leads will not work with later AR8200 S2 sets. All CC8200 leads now purchased do not have the purple wire connected and will work with any AR8200 set. To modify an early CC8200 lead to work with any set, simply cut the purple wire.

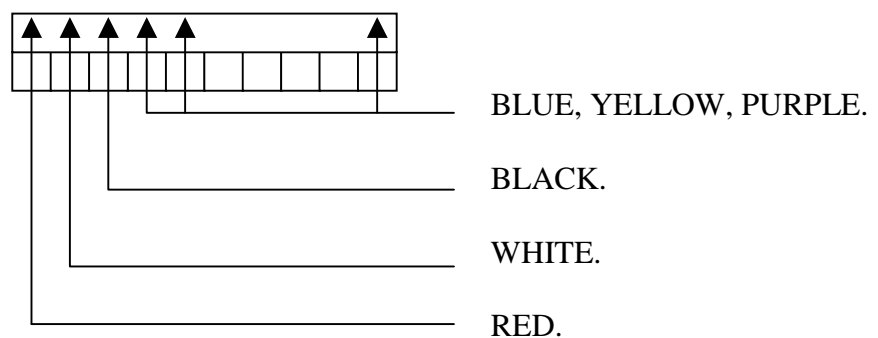

### INTERFACE PLUG, END VIEW.